

Side Channel pumps Self-priming, segmental type



Pump Systems Group

(ABN 38 027 981 316)
POSTAL: P O BOX 329, BAYSWATER VICTORIA, 3153
FACTORY 21 LONDON DRIVE, BAYSWATER, VICTORIA, 3153
Tel: 03 9762 3100



AEH 1201 ... 6108

Technical data

Capacity:	from 0,4 up to 35 m ³ /h
Delivery head:	from 6 up to 348 m
Speed:	1450 rpm (max. 1800 rpm)
Temperature:	max. 120 °C max. 180 °C for high temperature design (higher temperatures upon request)
Casing pressure:	PN 40
Shaft sealing:	stuffing box or mechanical seal
Flange connections:	DIN 2501 / PN 40
Direction of rotation:	clockwise (when seen from the drive end)

Application

The Sterling SIHI AEH pump is a self-priming side channel pump capable of handling gas along with the medium. The AEH is a Side Channel pump as per **DIN EN 734** and operates at a low noise level.

The AEH pumps were especially developed for difficult applications in all industry sectors and are thus applied when pure, turbid or aggressive media have to be pumped under difficult conditions without any problems.

The different material possibilities with uniform dimensions and performance characteristics as well as the standard exchangeable components, make the AEH particularly recommendable as universal pump for all possible pumping problems. This results in a wide application range in many sectors such as;

- Chemical industry,
- Petro-Chemical industry,
- Pharmaceutical industry,
- OEM,
- Oil industry,
- Food industry.

Design

Pumps of the series AEH have a segmental type construction with open vane wheel impellers. The pumps is available in a normal industrial design with one liquid surrounded slide bearing and one ball bearing or in a heavy-duty construction with a double ball bearing design.

The program comprises 6 sizes each with 1-8 stages. The existing material design allows an optimum rating for the respectively desired performance range and the pumping medium.

The applied hydraulic components are from our Modular Side Channel system (interchangeability of parts).

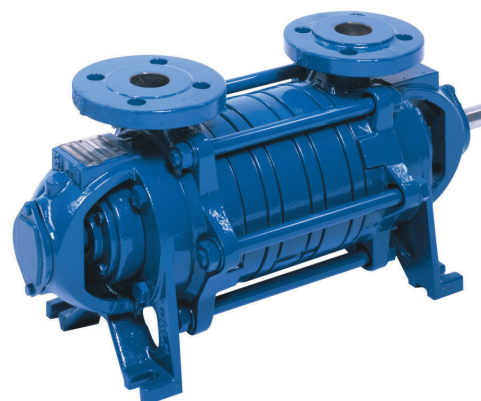

Construction

Casing pressure

Maximum 40 bar from -40 °C up to +120 °C.
Maximum 32 bar from +120 °C up to +180 °C.
Pressure stages for temperature as per DIN EN 1333.

Please observe

Technical rules and safety regulations:
Casing pressure = inlet pressure + delivery head at minimum pump capacity.

Position of branches

Suction and discharge branch point radially upwards.

Flanges

The flanges correspond to DIN EN 1092-2 / PN 40.
Flange design as per DIN 2512 with groove or drilled according to ANSI 150 or 300 lbs is basically possible.

Bearing

Either by a ball bearing and a liquid surrounded sleeve bearing (design A) or by two ball bearings (design B). The ball bearings are according to DIN 625 and greased for life.

Direction of rotation

Clockwise, when looking at the pump from the drive end.
Anti-clockwise is possible.

Shaft sealing

The shaft can be sealed by a stuffing box or a mechanical seal conform DIN EN 12756.
The shaft sealing is also available in a design suitable for heating or cooling of the stuffing box or the mechanical seal.

Double mechanical seal (back-to-back as well as tandem) or a quench design with throttle bush are available upon request.

The AEH can also be supplied with a magnetic coupling (for information see the separate catalogue).

Material design AEH

Cast iron and Ductile iron

Pos	Components	Material design					
		0A	0B	0F	1A	1B	1F
1060	Suction casing	EN-GJL-250			EN-GJS-400-18-LT		
1070	Discharge casing						
1090	Intermediate piece						
1140 1141							
2100	Shaft	X 20 Cr 13					
2350	Vane wheel impeller	CuZn40Al2	G-X 3 CrNiMoCuN 26 6 3 3	PAEK	CuZn40Al2	G-X 3 CrNiMoCuN 26 6 3 3	PAEK
3500	Bearing housing	EN-GJL-250			EN-GJL-250		
3550	Bearing bracket *				EN-GJS-400-18-LT		
4410	Mechanical seal casing	EN-GJL-250			EN-GJS-400-18-LT		
4510	Stuffing box casing						
5451	Bearing bush	EK 2203					

* Only for Design A

Stainless steel

Pos	Components	Material design	
		4B	4F
1060	Suction casing	G-X 6 CrNiMo 18 10	
1070	Discharge casing		
1090	Intermediate piece		
1140 1141			
2100	Shaft	X 5 CrNiMo 17 12 2	
2350	Vane wheel impeller	G-X 3 CrNiMoCuN 26 6 3 3	PAEK
3500	Bearing housing	EN-GJL-250 coated	
4410	Mechanical seal casing	G-X 6 CrNiMo 18 10	

Casing seal

The casing can be sealed with a liquid sealing compound or soft Teflon.

Drive

By electric motor, type of construction IM B3.

General comments

Side Channel pumps with the same hydraulic construction are manufactured in series as:

- AEH** With magnetic coupling, PN 40
- CEH** High duty pump, PN 40
Also available with magnetic coupling
- CEB** Vertical tank mounted pump, PN 25 with magnetic coupling
- CEV** Vertical tank mounted pump, PN 25 with mechanical seal (replacement for CVGP)
- AKH** Medium duty pump, PN 16
- AOH** Low duty pump with oval flanges, PN 10

Technical documents about these pump series will be readily supplied on request.

Sectional drawing and parts list AEH (typical)

AEH in design A

Stuffing box as well as (un)balanced mechanical seals are available

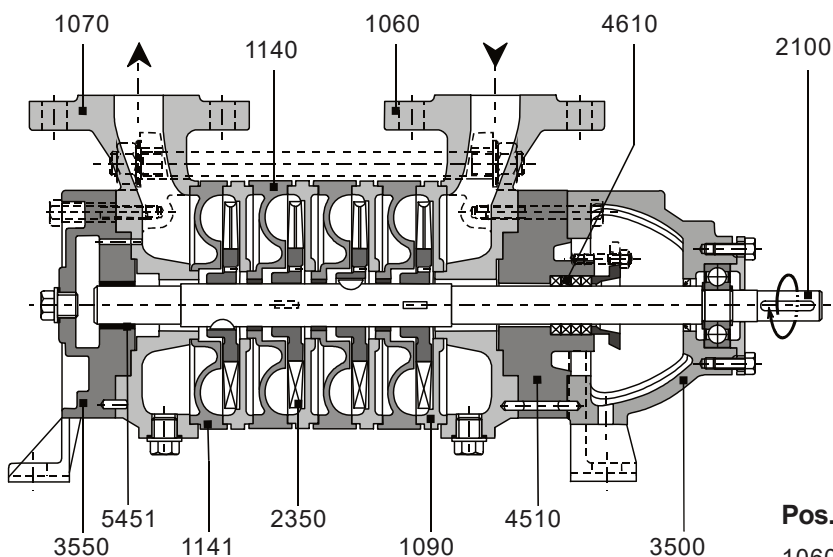

Pos.	Components
1060	Suction casing
1070	Discharge casing
1090	Suction intermediate piece
1140	Discharge intermediate piece
1141	Discharge intermediate piece
2100	Shaft
2350	Vane wheel impeller
3500	Bearing housing
3550	Bearing bracket
4330	Mechanical seal
4410	Mechanical seal casing
4420	Cooling insert
4510	Stuffing box casing
4610	Stuffing box
5451	Bearing bush

AEH in design B

Stuffing box as well as (un)balanced mechanical seals are available

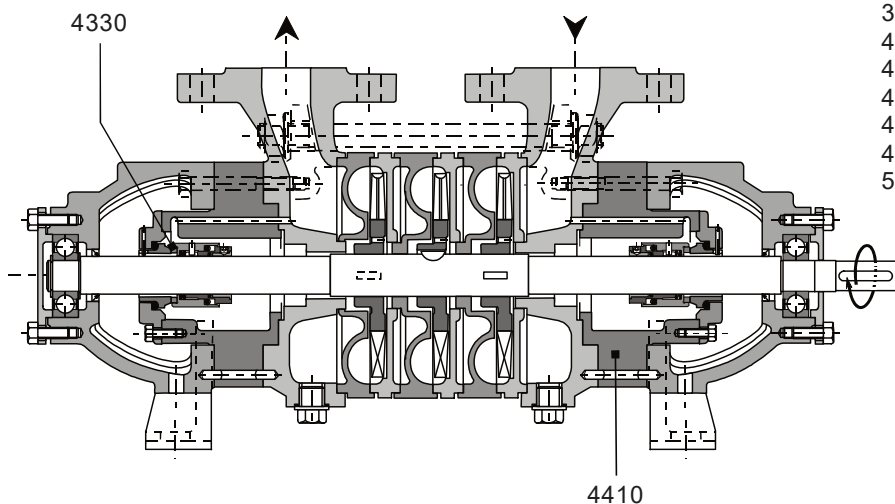

Cooled shaft sealing possibilities

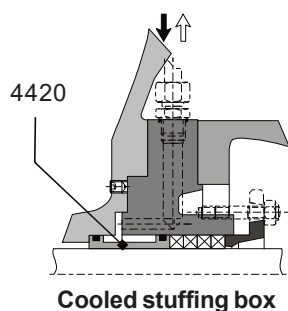

Cooled stuffing box

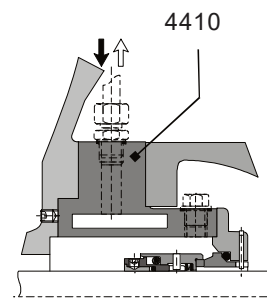

Cooled mechanical seal

All possible design combinations can be found in the delivery program

Performance range AEH

General conditions

Liquid: Water
 Density: 1 kg/dm³
 Viscosity: 1 cSt
 Temperature: 20 °C
 Atmospheric pressure: 1013 mbar

Characteristic tolerances

Capacity ± 5% - Delivery head ± 5% - Power + 10%
 For designs with a mechanical seal or a casing seal of soft Teflon, the tolerance for the delivery head is extended by 2% each.

Measuring standard

According to ISO 5198

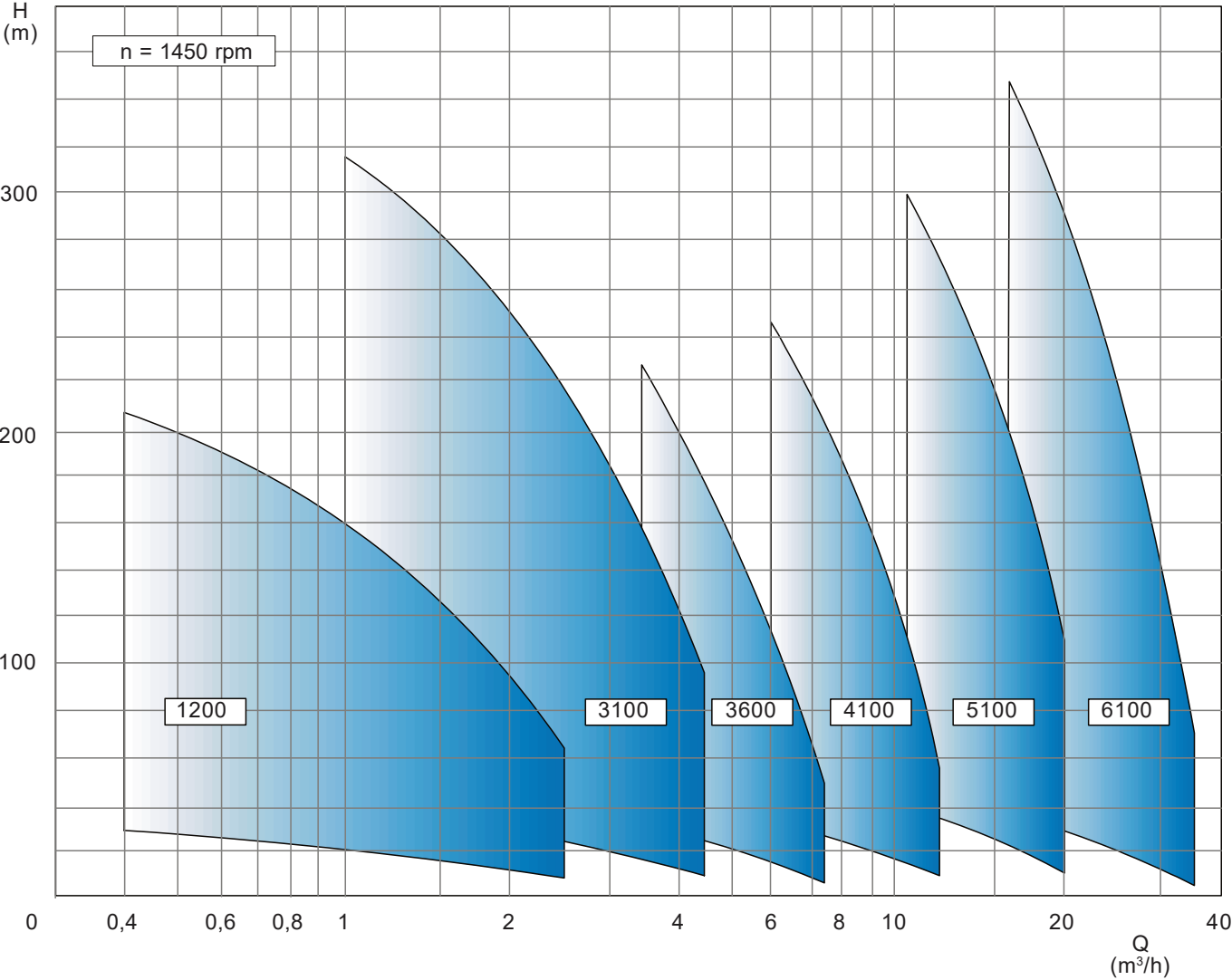

Dimension chart, Pump set drawing and Performance curves

AEH 1200

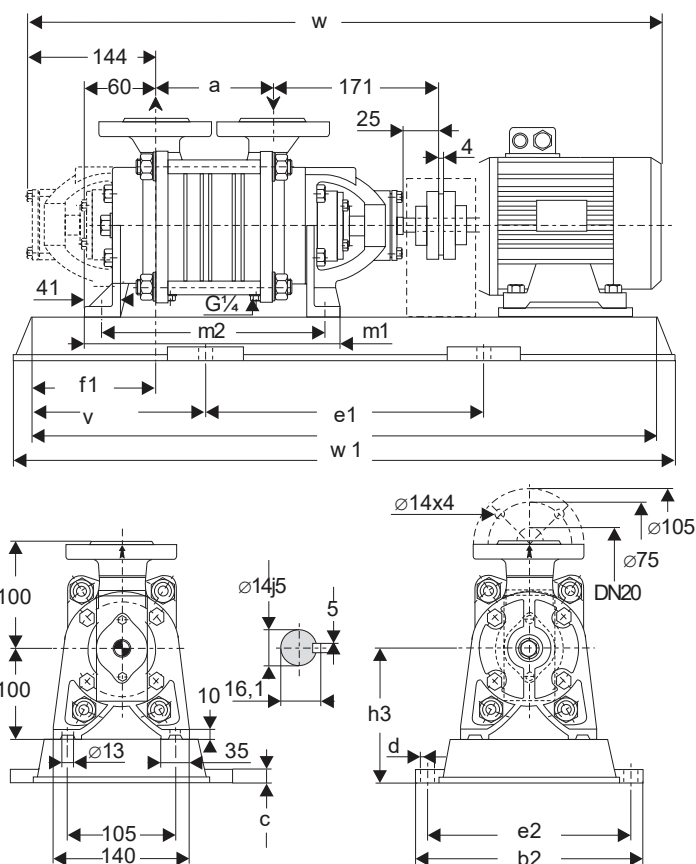
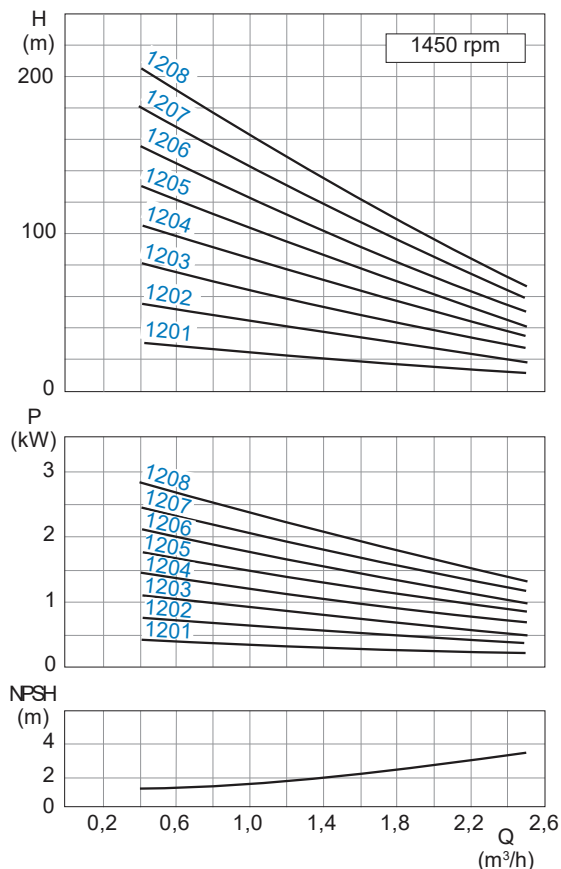

General:

Values are valid for water $\rho = 1 \text{ kg/dm}^3$ and $\nu = 1 \text{ cSt}$.

Characteristic tolerances:

Capacity $\pm 5\%$ - Delivery head $\pm 5\%$ - Power $+ 10\%$.
For designs with a mechanical seal or casing seal of soft Teflon, the tolerance for the delivery head is extended by 2% each.

Pump size	Motor		Base plate	Coupling	Weight		a	b2	c	d	e1	e2	v	f1	h3	m1	m2	w*	w1
	kW	size			pump	set													
1201	0.37	71	P008	B68	19	44	120	297	20	15	400	265	120	98	140	270	236	677	640
	0.55	80				47												711	
1202	0.55	80	P008	B68	20	48	120	297	20	15	400	265	120	98	140	270	236	711	640
	0.75	80				49												769	
	1.1	90S	P241	57	330	25	19	480	290	125	165	745	650						
1203	0.75	80	P210	B68	21	52	154	300	25	19	420	260	115	98	165	304	270	745	650
	1.1	90S				59												330	
	1.5	90L	P241	63	330	25	19	480	290	125	803	730							
1204	1.1	90S	P241	B68	23	61	188	330	25	19	480	290	125	98	165	338	304	837	730
	1.5	90L				65												360	
	2.2	100L	P272	76	360	540	320	140	878	820									
1205	1.1	90S	P272	B68	25	66	222	360	25	19	540	320	140	98	165	372	338	871	820
	1.5	90L				70												77	
	2.2	100L	77	912															
1206	1.5	90L	P272	B68	27	72	256	360	25	19	540	320	140	98	165	406	372	905	820
	2.2	100L				84												361	
	3	100L	P015	85	361	25	15	600	325	160	150	946	920						
1207	1.5	90L	P015	B68	29	79	290	361	25	15	600	325	160	98	150	440	406	939	920
	2.2	100L				86												87	
	3	100L	87	980															
1208	2.2	100L	P015	B80	31	89	324	361	25	15	600	325	160	98	150	474	440	1014	920
	3	100L				90												1014	

* Design B - dimensions depend on motor brand.
The weight of the pump in design A will be approximately 1 kg less.
The weight will be approximately 6% higher when using Stainless steel.

Dimension chart, Pump set drawing and Performance curves

AEH 3100

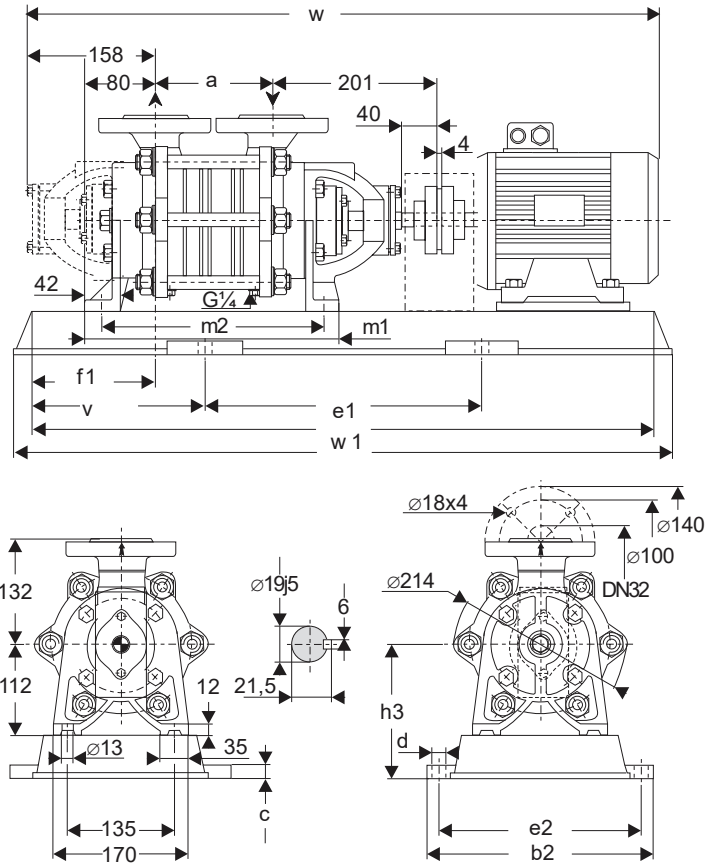
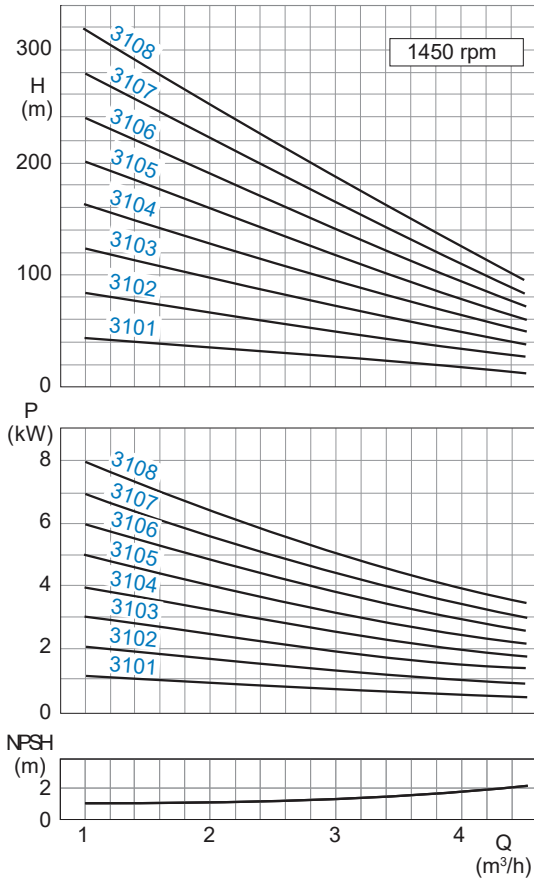

General:

Values are valid for water $\rho = 1 \text{ kg/dm}^3$ and $\nu = 1 \text{ cSt}$.

Characteristic tolerances:

Capacity $\pm 5\%$ - Delivery head $\pm 5\%$ - Power $+ 10\%$.
For designs with a mechanical seal or casing seal of soft Teflon, the tolerance for the delivery head is extended by 2% each.

Pump size	Motor		Base plate	Coupling	Weight		a	b2	c	d	e1	e2	v	f1	h3	m1	m2	w*	w1
	kW	size			pump	set													
3101	0.75	80	P241	B68	33	64	146	330	25	19	480	290	125	107	177	314	280	781	730
	1.1	90S				68												839	
3102	1.1	90S	P241	B68	35	70	146	330	25	19	480	290	125	107	177	314	280	839	730
	1.5	90L				72												880	
	2.2	100L	P272	B80	85	360	540	320	140	880	820								
3103	2.2	100L	P272	B80	37	89	186	360	25	19	540	320	140	107	177	354	320	920	820
	3	100L				90													
3104	2.2	100L	P015	B80	40	97	226	361	25	15	600	325	160	107	162	394	360	960	920
	3	100L				98												981	
	4	112M				116												1000	
3105	3	100L	P015	B80	44	102	266	361	25	15	600	325	160	107	162	434	400	1000	920
	4	112M				120					1021								
	5.5	132S	P017	B95	137	700	200	192	1097	1100									
3106	4	112M	P017	B80	49	139	306	361	25	15	700	325	200	107	172	474	440	1061	1100
	5.5	132S				B95												161	
	7.5	132M	171	1163															
3107	4	112M	P017	B80	53	144	346	361	25	15	700	325	200	107	172	514	480	1101	1100
	5.5	132S				B95												165	
	7.5	132M	205	1203															
3108	5.5	132S	P017	B95	57	199	386	361	25	15	700	325	200	107	192	554	520	1217	1100
	7.5	132M				209												1243	
	11	160M	P436	255	540	30	24	840	490	215	240	1335	1270						

* Design B - dimensions depend on motor brand.
The weight of the pump in design A will be approximately 2,5 kg less.
The weight will be approximately 6% higher when using Stainless steel.

Dimension chart, Pump set drawing and Performance curves

AEH 3600

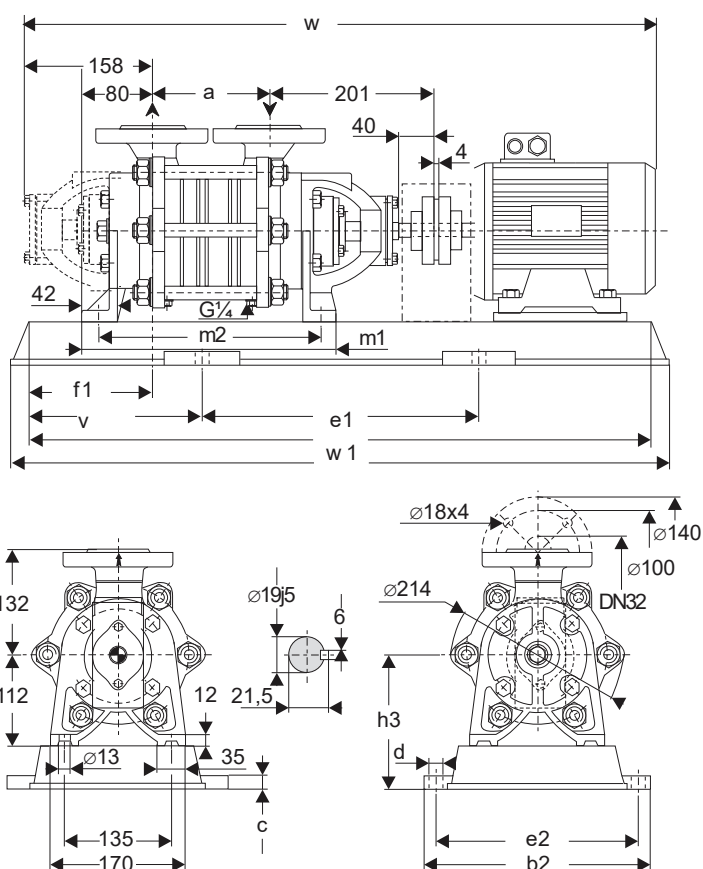
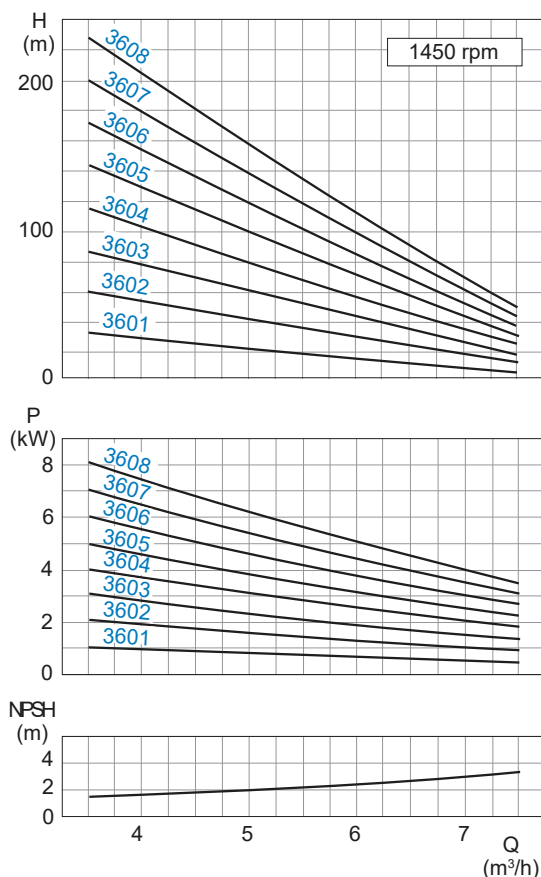

General:

Values are valid for water $\rho = 1 \text{ kg/dm}^3$ and $\nu = 1 \text{ cSt}$.

Characteristic tolerances:

Capacity $\pm 5\%$ - Delivery head $\pm 5\%$ - Power $+ 10\%$.
For designs with a mechanical seal or casing seal of soft Teflon, the tolerance for the delivery head is extended by 2% each.

Pump size	Motor		Base plate	Coupling	Weight		a	b2	c	d	e1	e2	v	f1	h3	m1	m2	w*	
	kW	size			pump	set												w*	w1
3601	0.75	80	P241	B68	30	64	146	330	25	19	480	290	125	107	177	314	280	781	730
	1.1	90S				68												839	
3602	1.5	90L	P241	B68	34	74	146	330	25	19	480	290	125	107	177	314	280	839	730
	2.2	100L	P272	B80		85												360	
3603	2.2	100L	P272	B80	39	89	186	360	25	19	540	320	140	107	177	354	320	920	820
	3	100L				90												941	
	4	112M				109												911	
3604	3	100L	P015	B80	43	98	226	361	25	15	600	325	160	107	162	226	394	960	920
	4	112M				116												981	
	5.5	132S	P017	B95		154												700	
3605	3	100L	P015	B80	46	102	266	361	25	15	600	325	160	107	162	266	434	1000	920
	4	112M				120												1021	
	5.5	132S	P017	B95		137												700	
3606	4	112M	P017	B80	49	139	306	361	25	15	700	325	200	107	172	306	474	1061	1100
	5.5	132S				B95												161	
	7.5	132M	171	1163															
3607	5.5	132S	P017	B95	53	165	346	361	25	15	700	325	200	107	192	514	480	1177	1100
	7.5	132M				205												1203	
3608	5.5	132S	P017	B95		57												209	
	7.5	132M			219		1243												
	11	160M	P436	255	540		30	24	840	490	215	240	1335	1270					

* Design B - dimensions depend on motor brand.
The weight of the pump in design A will be approximately 2,5 kg less.
The weight will be approximately 6% higher when using Stainless steel.

Dimension chart, Pump set drawing and Performance curves

AEH 4100

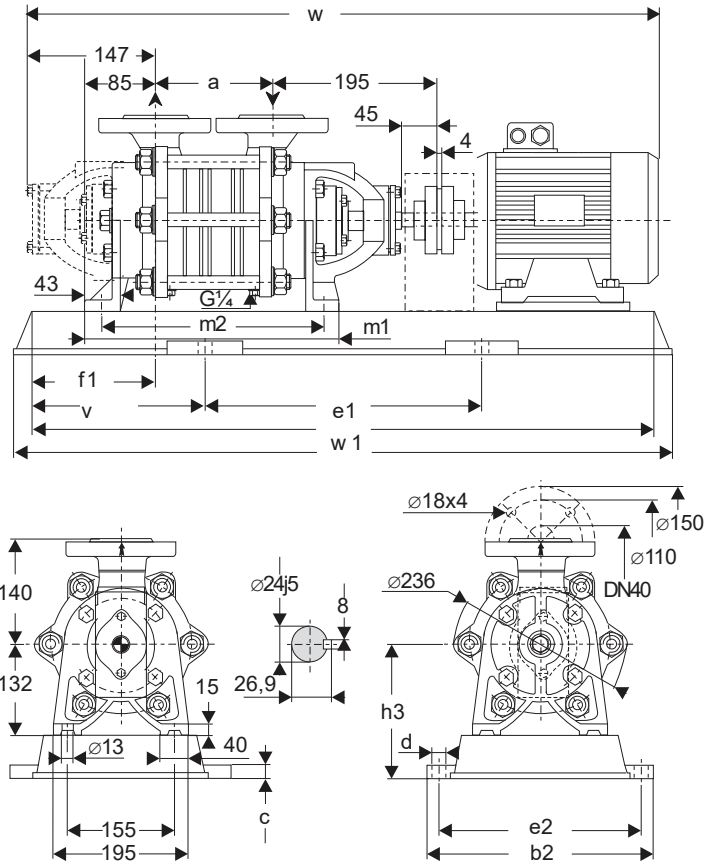
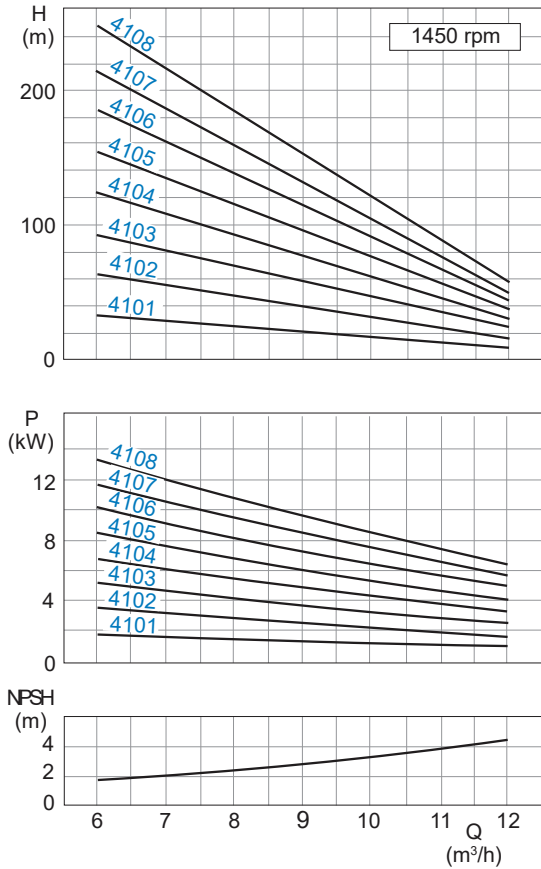

General:

Values are valid for water $\rho = 1 \text{ kg/dm}^3$ and $\nu = 1 \text{ cSt}$.

Characteristic tolerances:

Capacity $\pm 5\%$ - Delivery head $\pm 5\%$ - Power $+ 10\%$.
For designs with a mechanical seal or casing seal of soft Teflon, the tolerance for the delivery head is extended by 2% each.

Pump size	Motor		Base plate	Coupling	Weight		a	b2	c	d	e1	e2	v	f1	h3	m1	m2	w*	
	kW	size			pump	set												w*	w1
4101	1.5	90L	P241	B68	40	84	160	330	25	19	480	290	125	94	197	303	269	836	730
	2.2	100L	P272			95					540	320	140					877	820
4102	2.2	100L	P272	B80	47	101	215	360	25	19	540	320	140	94	197	358	324	932	820
	3	100L				102													
4103	4	112M	P015	B80	52	132	270	361	25	15	600	325	160	94	182	413	379	1008	920
	5.5	132S	P017			172					700	200	192		1084			1100	
4104	5.5	132S	P017	B95	61	175	325	361	25	15	700	325	200	94	192	468	434	1139	1100
	7.5	132M				185													
4105	5.5	132S	P017	B95	67	181	380	361	25	15	700	325	200	94	192	523	489	1194	1100
	7.5	132M				221													
	11	160M				275												490	
4106	7.5	132M	P385	B95	73	237	435	490	30	24	740	440	200	94	212	578	544	1275	1140
	11	160M	P436			272					540	840	490		215			240	1367
4107	7.5	132M	P436	B95	79	234	490	540	30	24	840	490	215	94	212	633	599	1330	1270
	11	160M				278													
	15	160L				P487									314			610	35
4108	11	160M	P487	B95	85	298	545	610	35	28	940	550	240	94	260	688	654	1477	1420
	15	160L		B110		319												1539	

* Design B - dimensions depend on motor brand.
The weight of the pump in design A will be approximately 2,5 kg less.
The weight will be approximately 6% higher when using Stainless steel.

Dimension chart, Pump set drawing and Performance curves

AEH 5100

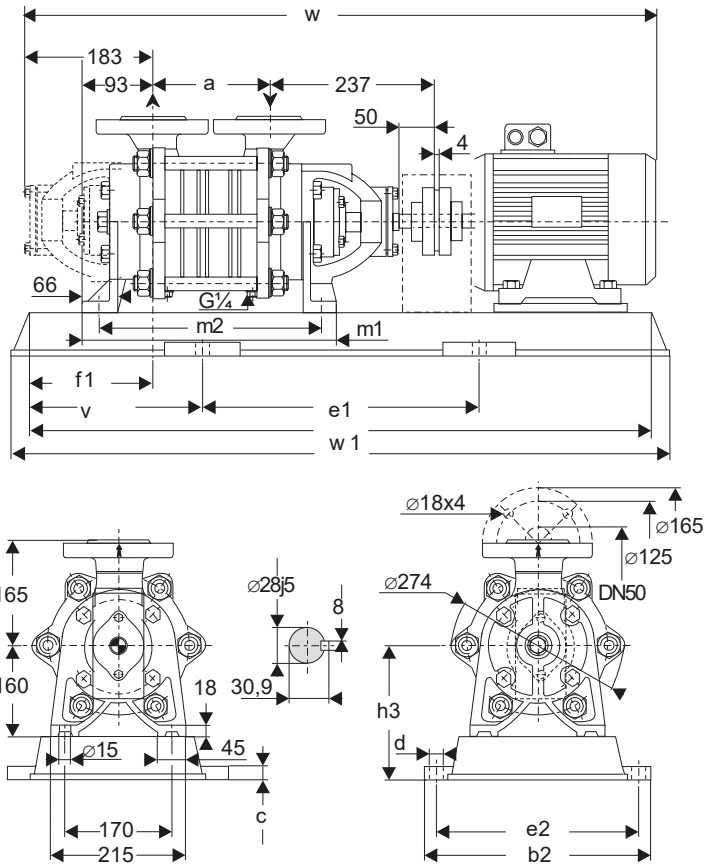
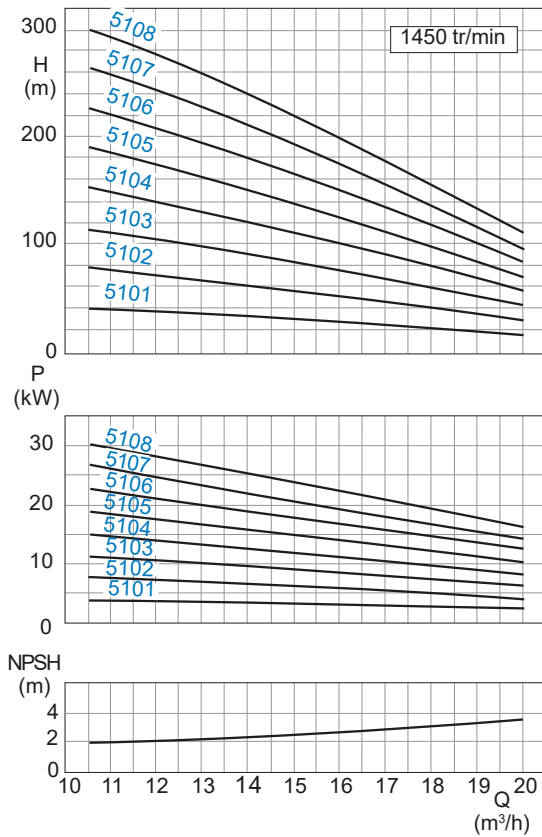

General:

Values are valid for water $\rho = 1 \text{ kg/dm}^3$ and $v = 1 \text{ cSt}$.

Characteristic tolerances:

Capacity $\pm 5\%$ - Delivery head $\pm 5\%$ - Power $+ 10\%$.
For designs with a mechanical seal or casing seal of soft Teflon, the tolerance for the delivery head is extended by 2% each.

Pump size	Motor		Base plate	Coupling	Weight		a	b2	c	d	e1	e2	v	f1	h3	m1	m2	w*	w1
	kW	size			pump	set													
5101	3	100L	P015	B80	65	118	175	361	25	15	600	325	160	118	210	369	331	970	920
	4	112M				137												991	
5102	5.5	132S	P017	B95	73	184	250	361	25	15	700	325	200	118	220	444	406	1142	1100
	7.5	132M				194												1168	
	11	160M	P385	B95	85	278	325	490	30	24	740	440	200	118	240	519	481	1260	1140
5103	7.5	132M	P017	B95	85	235	325	361	25	15	700	325	200	118	220	519	481	1243	1100
	11	160M	280			1335													
	15	160L	P436	B110	298	540	30	24	840	490	215	118	240	519	481	1397	1270		
5104	11	160M	P436	B95	92	290	400	540	30	24	840	490	215	118	240	594	556	1410	1270
	15	160L	P487	B110		325												610	
5105	15	160L	P487	B110	103	336	475	610	35	28	940	550	240	118	260	669	631	1547	1420
	18.5	180M				357												1609	
	22	180L	B125	377	1609														
5106	15	160L	P538	B110	115	387	550	660	35	28	1060	600	280	118	260	744	706	1622	1620
	18.5	180M				408												1684	
	22	180L				428												1684	
5107	30	200L	P538	B125	130	509	625	660	35	28	1060	600	280	118	280	619	781	1759	1620
	18.5	180M				419												1817	
	22	180L				439												1817	
5108	22	180L	P538	B125	141	480	700	660	35	28	1060	600	280	118	280	894	856	1834	1620
	30	200L				S389												533	

* Design B - dimensions depend on motor brand.
The weight of the pump in design A will be approximately 5 kg less.
The weight will be approximately 6% higher when using Stainless steel.

Dimension chart, Pump set drawing and Performance curves

AEH 6100

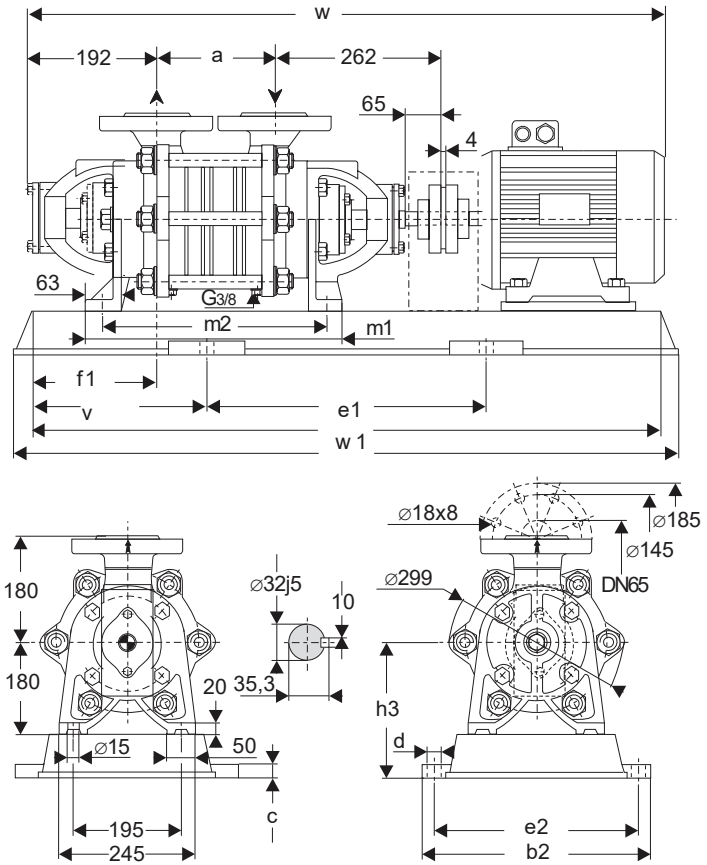
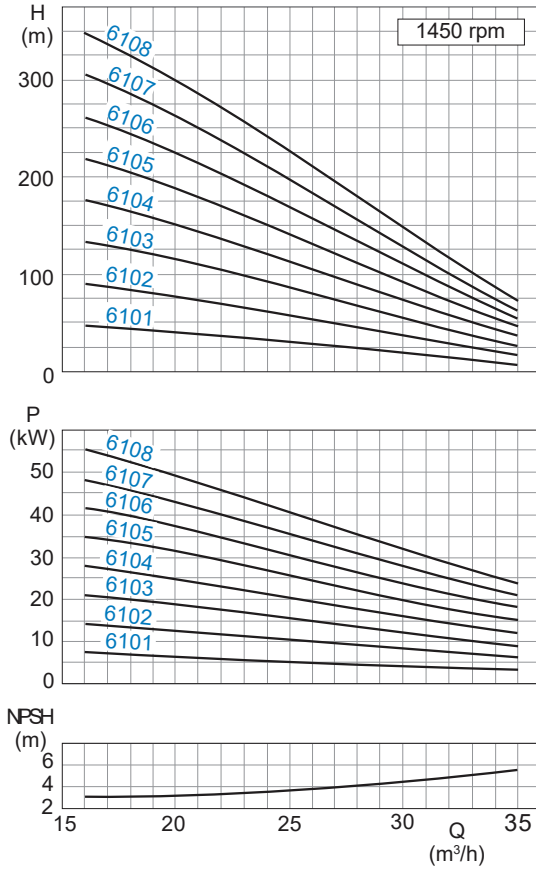

General: Values are valid for water $\rho = 1 \text{ kg/dm}^3$ and $\nu = 1 \text{ cSt}$.

Characteristic tolerances: Capacity $\pm 5\%$ - Delivery head $\pm 5\%$ - Power $+ 10\%$.
For designs with a mechanical seal or casing seal of soft Teflon, the tolerance for the delivery head is extended by 2% each.

Pump size	Motor		Base plate	Coupling	Weight		a	b2	c	d	e1	e2	v	f1	h3	m1	m2	w*	w1						
	kW	size			pump	set																			
6101	5.5	132S	P017	B95	74	198	195	361	25	15	700	325	200	129	240	412	374	1121	1100						
	7.5	132M				218												1147							
6102	11	160M	P385	B95	87	305	285	490	30	24	740	440	200	129	260	502	464	1329	1140						
	15	160L	P436	B110		317					840	490						215		1391	1270				
6103	18.5	180M	P487	B110	99	363	375	610	35	28	940	550	240	129	280	592	554	1543	1420						
	22	180L		B125		383												1060		600	280	1691	1620		
6104	22	180L	P487	B125	112	396	465	610	35	28	940	550	240	129	280	682	644	1633	1420						
	30	200L	P538			517					1060	600			280			300		1691	1620				
6105	30	200L	P538	B125	124	529	555	660	35	28	1060	600	280	129	300	772	734	1781	1620						
	37	225S		B140		598									325			1846							
6106	30	200L	S389	B125	137	544	645	540	40	28	1200	490	300	129	300	862	824	1871	1800						
	37	225S	14206	B140		542		640				690			300			129		343	1936				
	45	225M				602																730	310	300	1961
6107	30	200L	S609	B125	149	556	735	740	40	28	1200	670	310	129	300	952	914	2026	1950						
	37	225S	14208	B140		545									740			690		325	129	343	2121		
	45	225M				612																		1300	368
	55	250M				14209																		B160	664
6108	37	225S	14211	B140	162	584	825	740	40	28	1300	690	350	129	343	1042	1004	2116	2000						
	45	225M				651							350					2116		2000					
	55	250M				14212							B160					702		400	368	2211	2100		

* Dimensions depend on motor brand.
The weight will be approximately 6% higher when using Stainless steel.

It is the policy of Sterling Fluid Systems to seek continually for ways to improve its products and the right is reserved to alter specifications at anytime without prior notice.

Sterling SIHI Side Channel pumps

Sterling Fluid Systems offers an extensive Side Channel pump range under its brand name Sterling SIHI. Sterling Fluid Systems has more than 80 years of experience in manufacturing, installation and support of Side Channel pumps. The Sterling SIHI Side Channel pumps can be found in a wide application range for the:

- Chemical market
- Pharmaceutical industry
- Petrochemical industry
- Food industry
- Ship yards
- LPG industry
- and many more ...

The Sterling SIHI Side Channel pump range

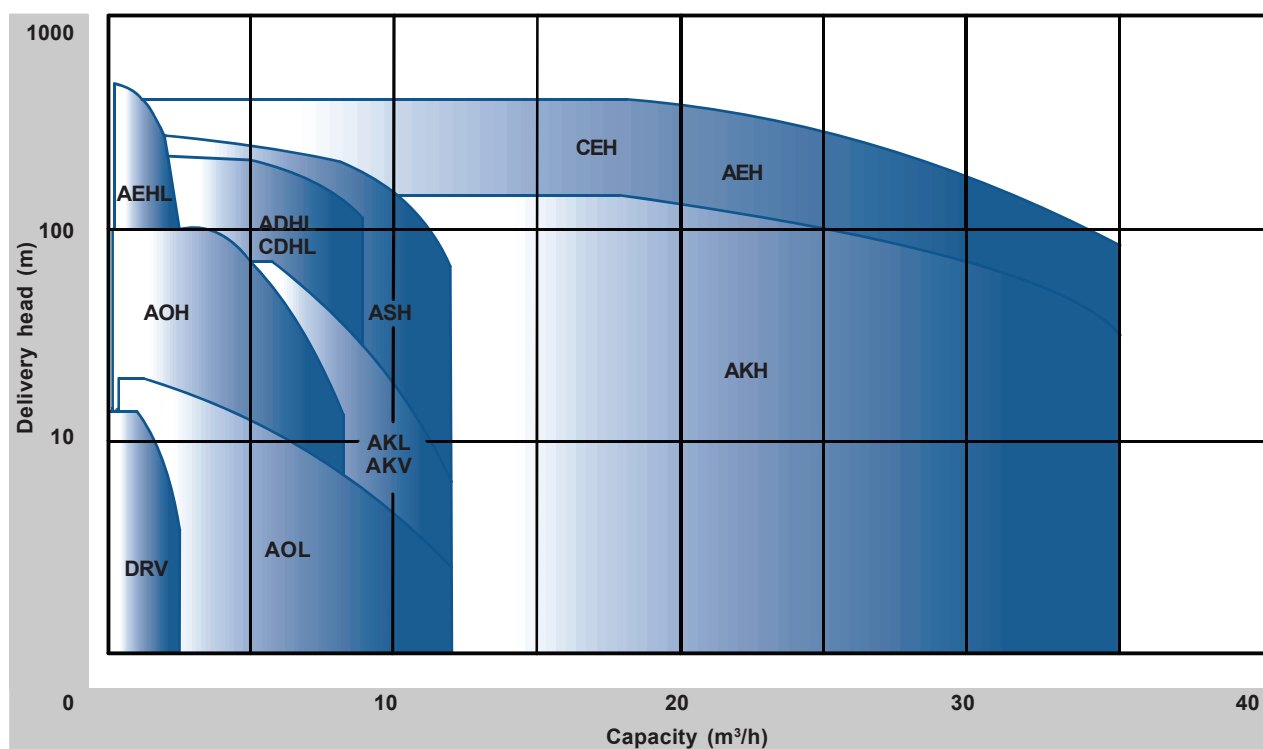

The benefits of the Sterling SIHI Side Channel pumps

- Self priming
- Gas handling
- High-resistant materials
- Performance curve characteristics
- High efficiency
- Low NPSH_R value
- Modular hydraulic system

The Sterling SIHI Side Channel pumps comply with the highest demands of our customers and are the best solution for the handling of liquids under critical physical conditions.