



SIHI LEMD

Sizes 27, 52, 92, 127, 162, 252, 327, 427

Pressure range: 33 to 1013 mbar abs / up to 28.9 vac. inHg

Suction volume flow: 5 to 450 m³/h / 2.9 to 265 cfm

Design

Flowserve SIHI liquid ring vacuum pumps are displacement pumps of uncomplicated and robust construction with the following particular features:

- Handling of nearly all gases and vapours
- Optimized for handling of additional liquid carry-over
- Non-polluting due to nearly isothermal compression
- Oil-free, as no lubrication in the working chamber
- Easy maintenance and reliable operation
- Low noise and nearly free from vibration
- Protection against cavitation as standard
- Incorporated central drain
- Standard motors, future-proof and conform with NEMA Premium-Efficiency and IE3, IE4, etc.

The Flowserve SIHI liquid ring vacuum pumps LEMD are single-stage ones.



NOTE

During operation the pump must continuously be supplied with service liquid, normally water, in order to eliminate the heat resulting from the gas compression and to replenish the liquid ring, because part of the liquid is leaving the pump together with the gas. This liquid can be separated from the gas in a liquid separator.

It is possible to reuse the service liquid. The pumps are equipped with a device by which the contaminated service liquid can continuously be drained during operation (central drain), if necessary.

The direction of rotation is clockwise, when looking from the drive on the pump

APPLICATION

Handling and exhausting of dry and humid gases, entrained liquid can be handled during normal duty. The pumps are applied in all fields where a pressure of 33 to 900 mbar abs / 28.9 to 3.4 vac. inHg must be created by robust vacuum pumps.

GENERAL TECHNICAL DATA

Pump type	unit	LEM 27	LEM 52	LEM 92	LEM 127	LEM 162	LEM 252	LEM 327	LEM 427
Speed	50 Hz 60 Hz	2900				1450			
	rpm	3500				1750			
Maximum Overpressure	bar / psi	0.3 / 4.35							
Permissible pressure difference between suction and discharge side	max. min. bar / psi	1.1 / 15.95 0.2 / 2.9							
Hydraulic test pressure (overpressure)	bar / psi	3.0 / 43.51							
Moment of inertia of rotating parts of pump and water	kg · m² lb · ft²	0.003 0.07	0.005 0.12	0.007 0.17	0.009 0.21	0.070 1.66	0.097 2.30	0.140 3.32	0.210 4.98
Acoustic emission level at 80 mbar / 27 vac. in Hg suction pressure and 1 m / 3 feet distance	dB (A)	64	70	69	70	73	72	69	74
Maximum gas temperature	dry °C / °F saturated °C / °F	200 / 392 100 / 212							
Service liquid	°C / °F	60 / 140							
max. perm. Outlet temperature - Material 0F/VP	°C / °F	80 / 176							
max. perm. Outlet temperature - Material 0E/VA	°C / °F	10 / 50							
min. perm. Inlet temperature	mm²/s / ft²/s	4 / 4.3 · 10 ⁻⁵							
max. viscosity	kg/m³ / lb/US.liq.gal	1200 12							
max. density	Liter	0.5	0.6	1.0	1.1	2.9	3.9	5.9	7.2
Liquid capacity up to middle of shaft	US.liq.gal	.13	.16	.26	.29	.76	1.0	1.6	1.9
Maximum flow resistance of the heat exchanger	bar / psi	0.2 / 2.9							

The combination of several limiting values is not admissible.

Features

Robust and reliable

- Suction volume flow up to 450 m³/h / 265 cfm
- Suction pressure down to 33 mbar abs / 28.9 vac. inHg
- Cavitation and corrosion resistant impeller
- Handling of additional liquid carryover
- Integrated pre-condenser with high performance
- Enhanced life time

Based on standard motor design

- IMB 34 and 35 standard design
- Efficiency class to IEC IE3, IE4 and NEMA premium efficiency
- Different voltage ranges, frequencies and protection classes
- Various certificates, for example ATEX, CSA, UR, CC, etc.
- Further special requirements

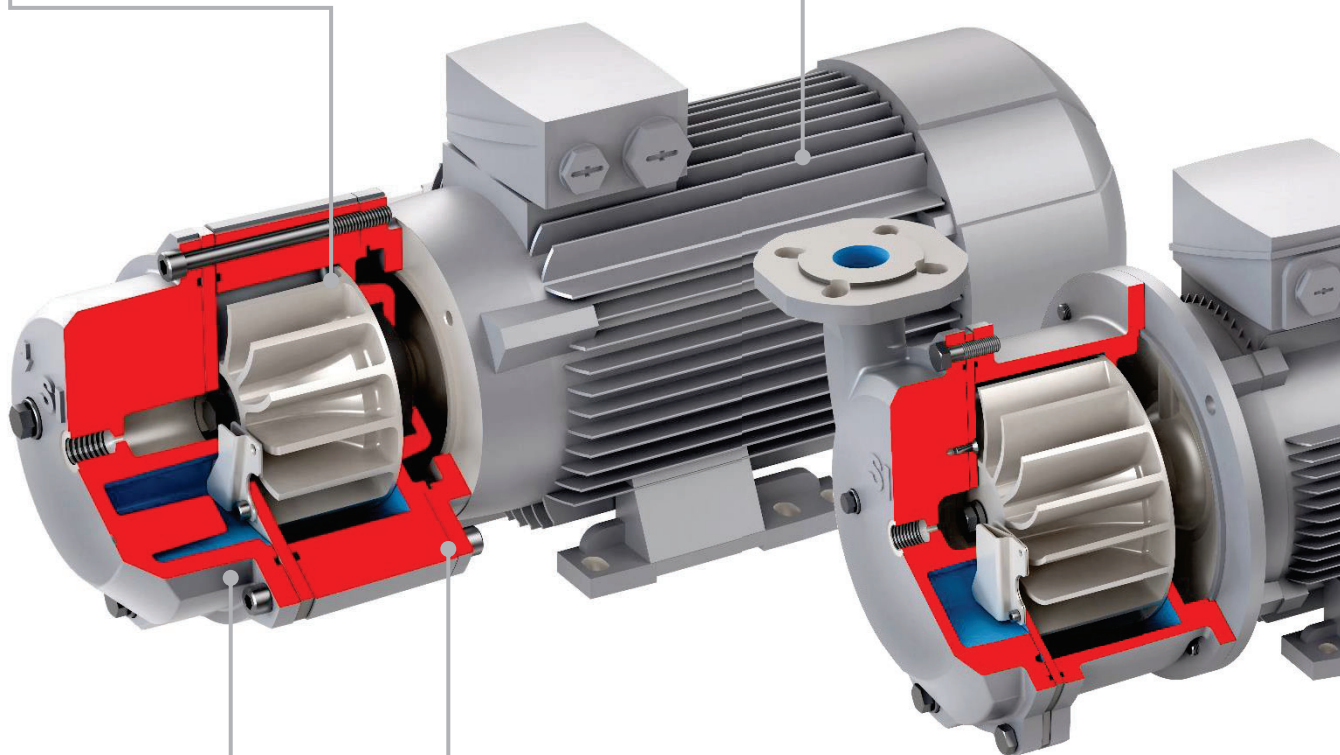

Ready for ATEX

- Built-in measurement connections
- Level monitoring for start-up
- Temperature monitoring during operation
- No special piping, adaptors and fittings required
- Simple and economic monitoring for ATEX up to Zone 1

Compact and maintenance friendly

- Connections top IN / top OUT or inline
- Minimal space required
- Flexible inlet and outlet connections
- Motor bearings greased for lifetime
- Long-life mechanical seal
- Easy maintenance



Interchangeability with former LEM series

- Same performance
- No influence regarding system performance
- No process changes necessary

Sectional Drawing

LEM 27, 52, 92, 127, 162*
with Threaded connections

LEM 162*, 252, 327, 427
with Flanged connections

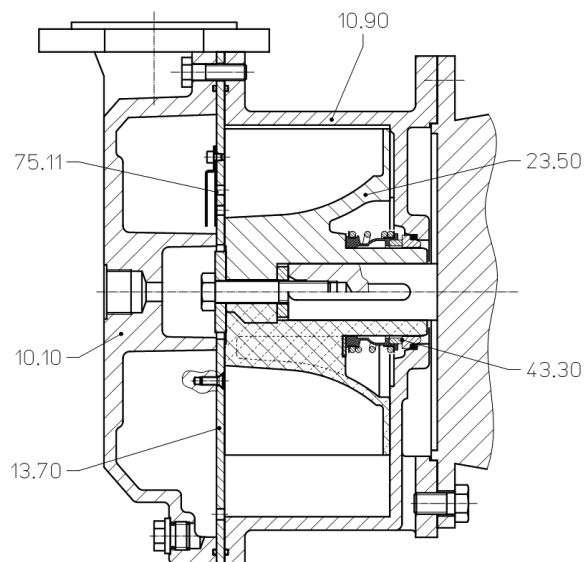
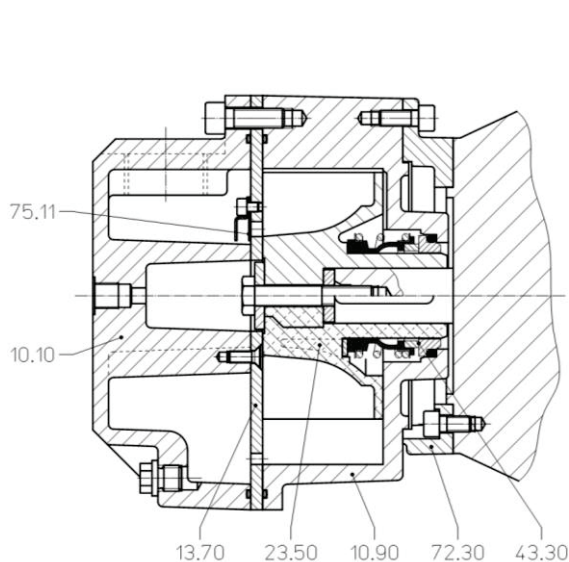

Materials

Pos.	Components	Material design			
		0F	0E	VP	VA
10.10	Vacuum casing	0.6025 Cast iron		1.4408 316 SS	
10.90	Central body	0.6025 Cast iron		1.4408 316 SS	
13.70	Guide disc	1.4404 316 SS		1.4404 316 SS	
23.50	Impeller	non-reinforced plastic - Engineered Polymer - POM	1.4404 316 SS	Non-reinforced plastic - Engineered Polymer - POM	1.4404 316 SS
43.30	Mechanical Seal LEM 27, 52 Mechanical Seal LEM 92 to 427	Carbon / Al-Oxide / Perbunan Carbon / SiC / Perbunan		Carbon / Al-Oxide / Viton Carbon / SiC / Viton	
72.30	Motor intermediate flange	0.6025 Cast iron		1.4408 316 SS	
75.11	Valve plate	PTFE			

* LEMD 162 with threaded connections (vertically upwards) is only available in material design 0F and 0E.
LEM 162 with flanged connections is only available in material design VP and VA.

Performance Characteristics LEM 27, 52, 92, 127

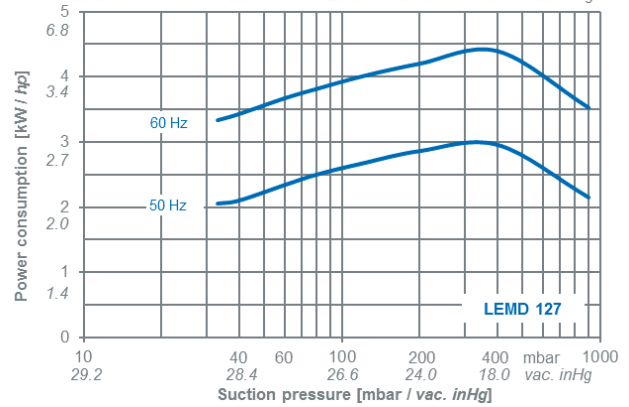
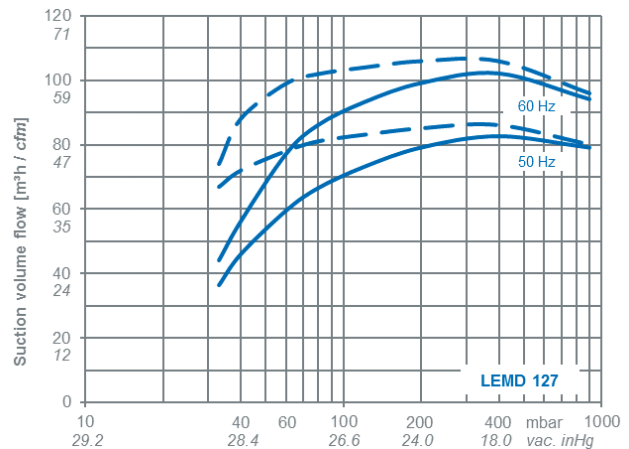
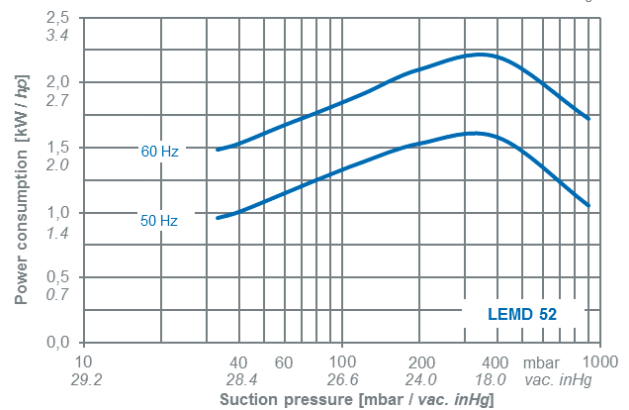
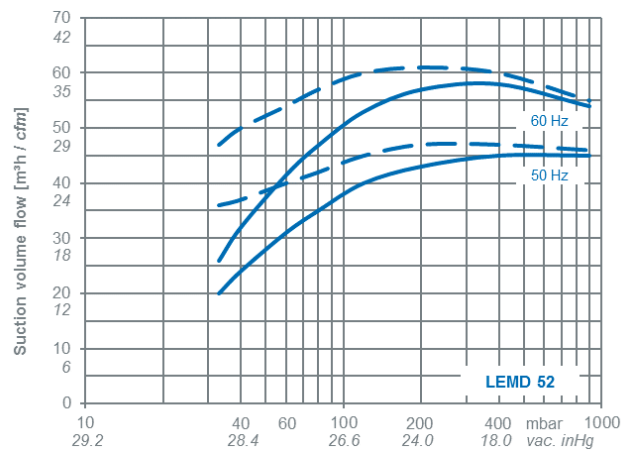
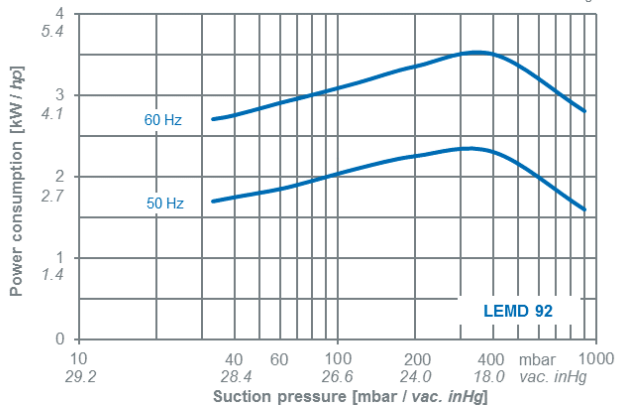
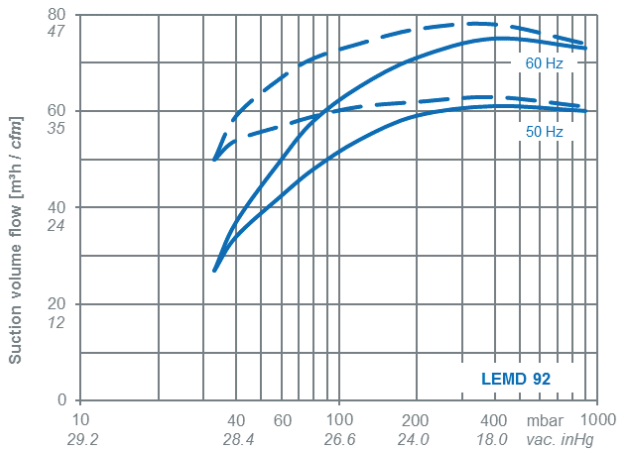
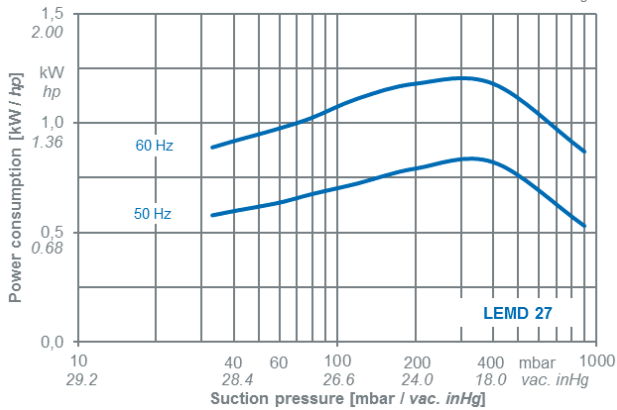
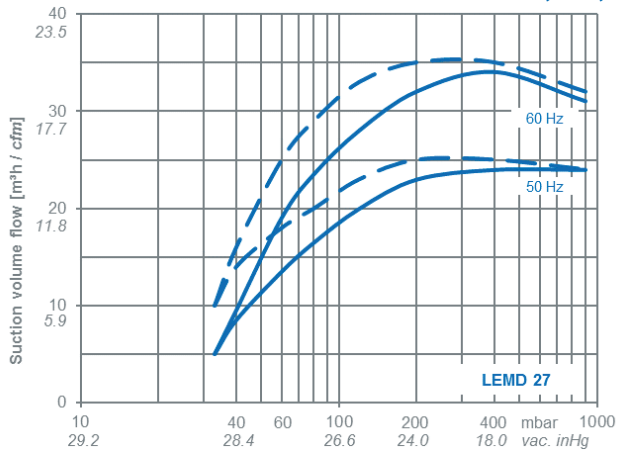

The operating data is valid under the following conditions:

- Process medium:
 - dry air: 20°C / 68°F
 - steam saturated air: 20°C / 68°F
- Service liquid:
 - water: 15°C / 59°F

Pressure of gas to be evacuated = 1013 mbar / 0 vac. inHg (atmosph. pressure), suction volume is related to suction pressure. Tolerance 10%.

Performance Characteristics LEM 162, 252, 327, 427

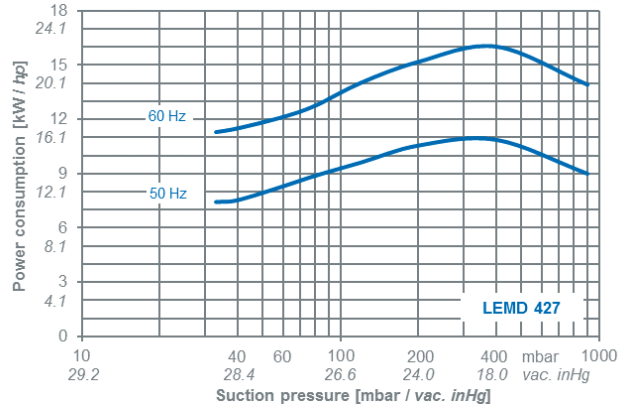
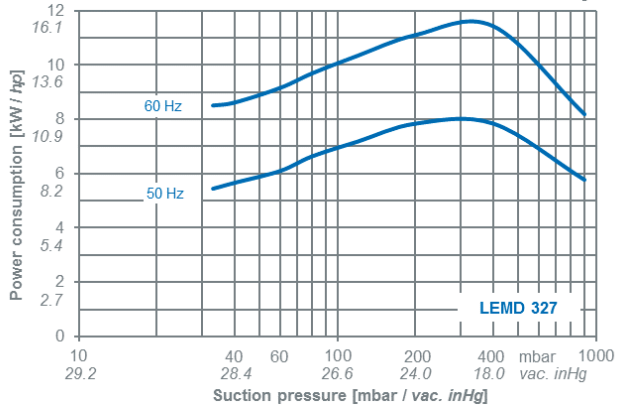
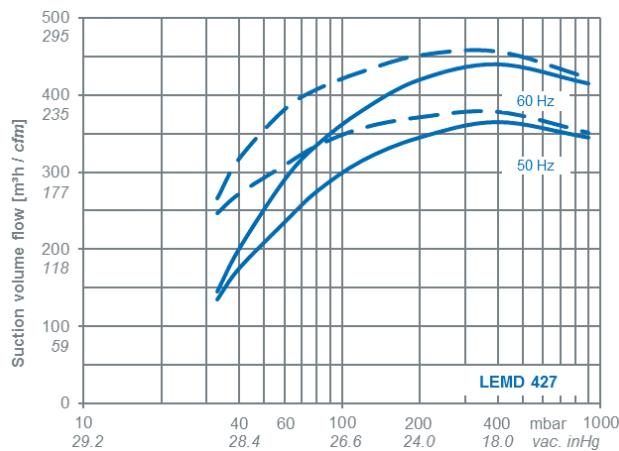
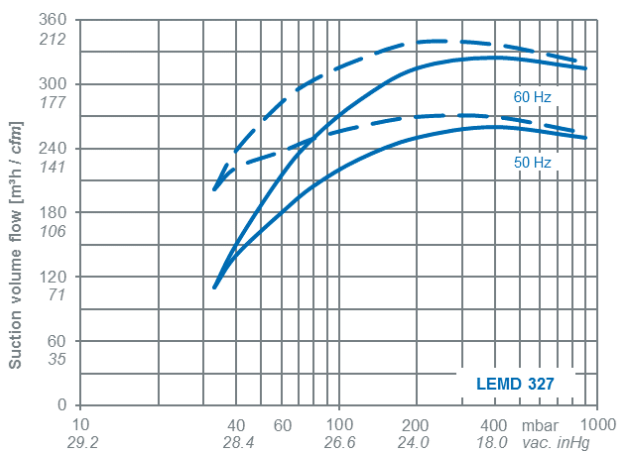
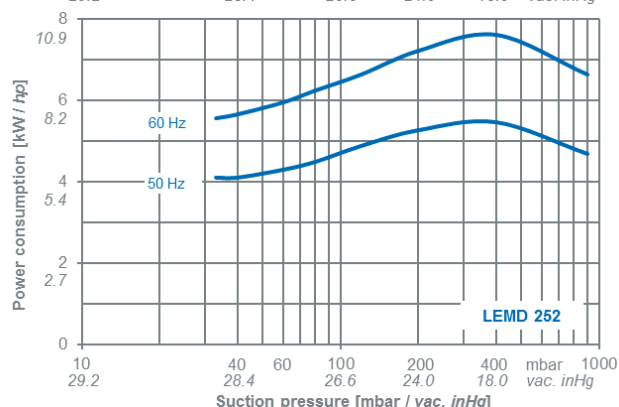
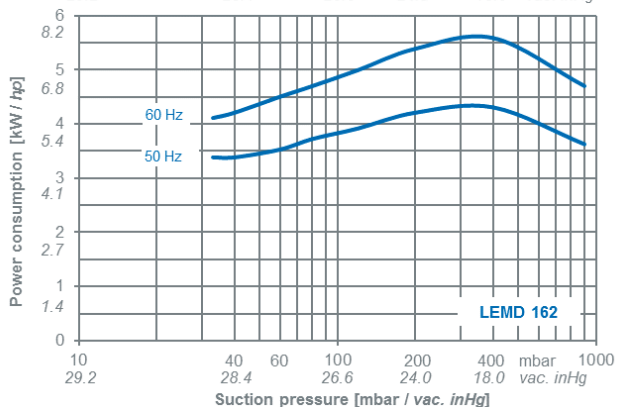
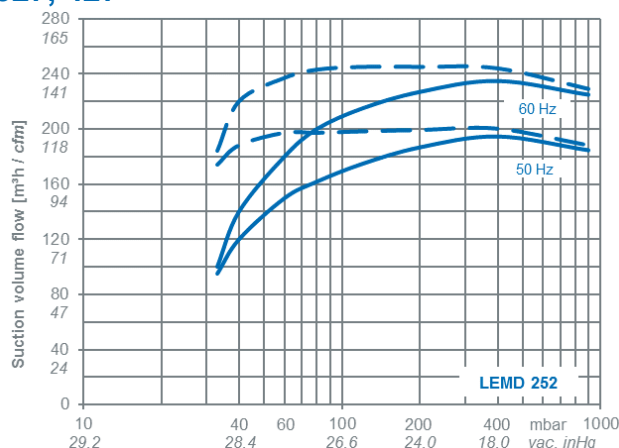
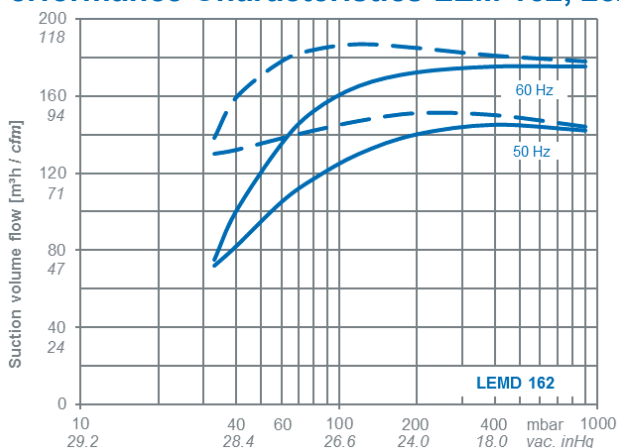

The operating data is valid under the following conditions:

- Process medium:
 - dry air: 20°C / 68°F
 - steam saturated air: 20°C / 68°F
- Service liquid:
 - water: 15°C / 59°F

Pressure of gas to be evacuated = 1013 mbar / 0 vac. inHg (atmosph. pressure), suction volume is related to suction pressure. Tolerance 10%.

Dimensions LEM 27, 52, 92, 127 with Threaded connections

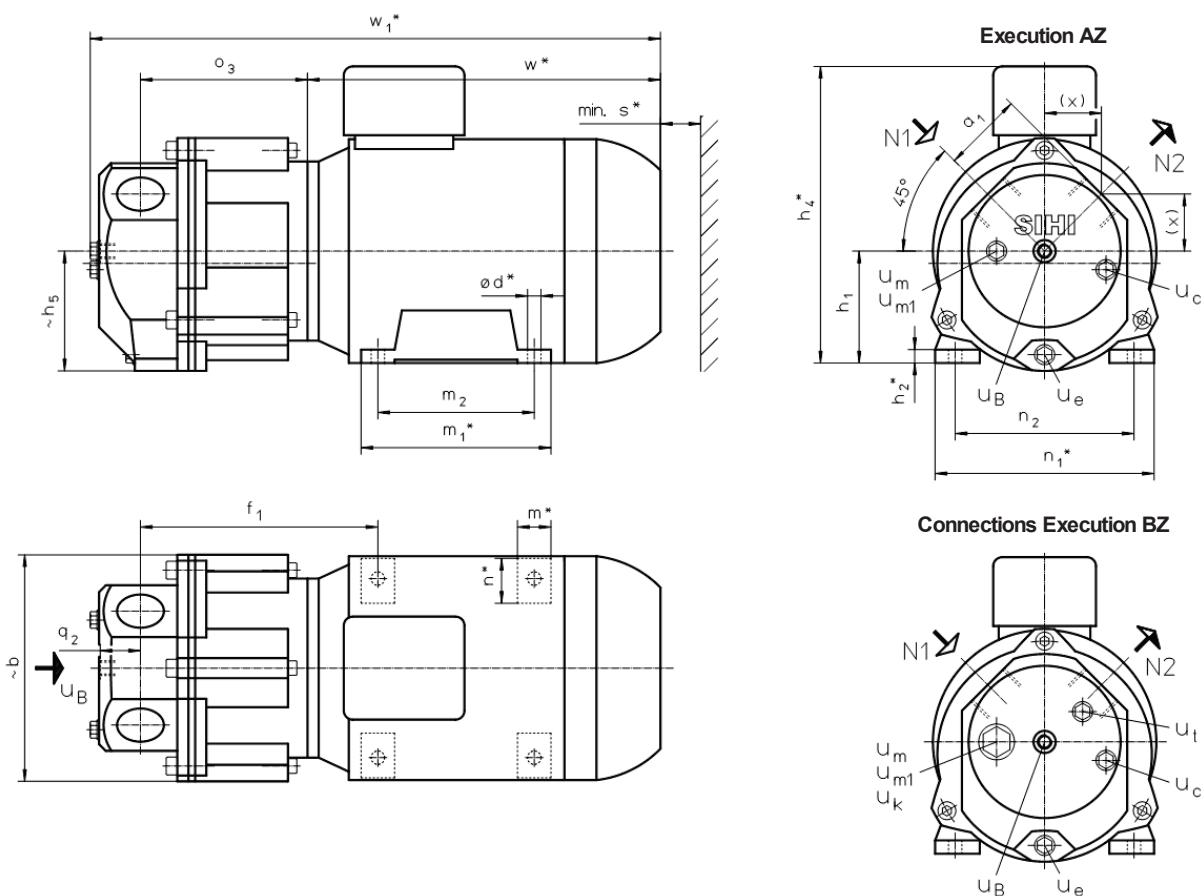

Dimensions in mm

	Motor size	a ₁	b	d*	f ₁	h ₁	h ₂ *	h ₄ *	h ₅ *	m*	m ₁ *	m ₂	n*	n ₁ *	n ₂	o ₃	q ₂	s*	w*	w ₁ *	x	appr. weight [kg]
LEM 27	80	60	173	10	162.5	80	8	216	90	28	124	100	32	155	125	112.5	27.5	30	236	385	42.4	30
LEM 52	90 S 90 L		179		187.5	90	9	245		24	146		35	170	140	141.5		33	269	447		40
LEM 92	100 L 112 M	72	202	12	208.5	100	12	265	107	30	170	140	40	196	160	145.5	36	36	316	507	50.9	52
LEM 127	100 L 112 M		220		215.5	112		297		32			46	220	190			41	333	524		60
			202		212.5	100		265		30			40	196	160	149.5		36	316	511		52
			220		219.5	112		297		32			46	220	190			41	333	528		60

Dimensions in inch

	Motor size	a ₁	b	d*	f ₁	h ₁	h ₂ *	h ₄ *	h ₅ *	m*	m ₁ *	m ₂	n*	n ₁ *	n ₂	o ₃	q ₂	s*	w*	w ₁ *	x	appr. weight [lb]
LEM 27	80	2.36	6.80	0.39	6.4	3.15	0.31	8.48	3.54	1.10	4.88	3.94	1.26	6.10	4.92	4.43	1.08	1.18	9.29	15.16	1.67	66
LEM 52	90 S 90 L		7.05		7.38	3.54	0.35	9.65		0.94	5.75		4.92	1.38	6.69	5.51		5.57	1.30	10.59		17.6
LEM 92	100 L 112 M	2.83	7.97	0.47	8.21	3.94	0.47	10.4	4.21	1.18	6.69	5.51	1.57	7.72	6.30	5.73	1.42	1.42	12.44	19.94	2.0	115
LEM 127	100 L 112 M		8.66		8.48	4.41		11.6		1.26			1.81	8.66	7.48			1.61	13.11	20.61		132
			7.97		8.37	3.94		10.4		1.18			1.57	7.72	6.30	5.89		1.42	12.44	20.10		115
			8.66		8.64	4.41		11.6		1.26			1.81	8.66	7.48			1.61	13.11	20.77		132

Other motors on request

* Dimensions dependent upon motor supplier

Dimensions LEM 27, 52, 92, 127 with Threaded connections

Connections

LEM	Execution AZ		Execution BZ	
	27, 52	92, 127	27, 52	92, 127
N 1 = Gas inlet	G 1	G 1 ¼	G 1	G 1 ¼
N 2 = Gas outlet				
u _B = Connection for service liquid control	G ¼			
u _c = Connection for cavitation protection				
u _e = Connection for drain				
u _m = Connection for manometer	G ¼		G ¾	
u _{m1} = Connection for service liquid level				
u _k = Connection for condensation liquid	-		G ¾	
u _t = Connection for thermometer	-		G ¼	

Dimensions LEM 162 with Threaded connections

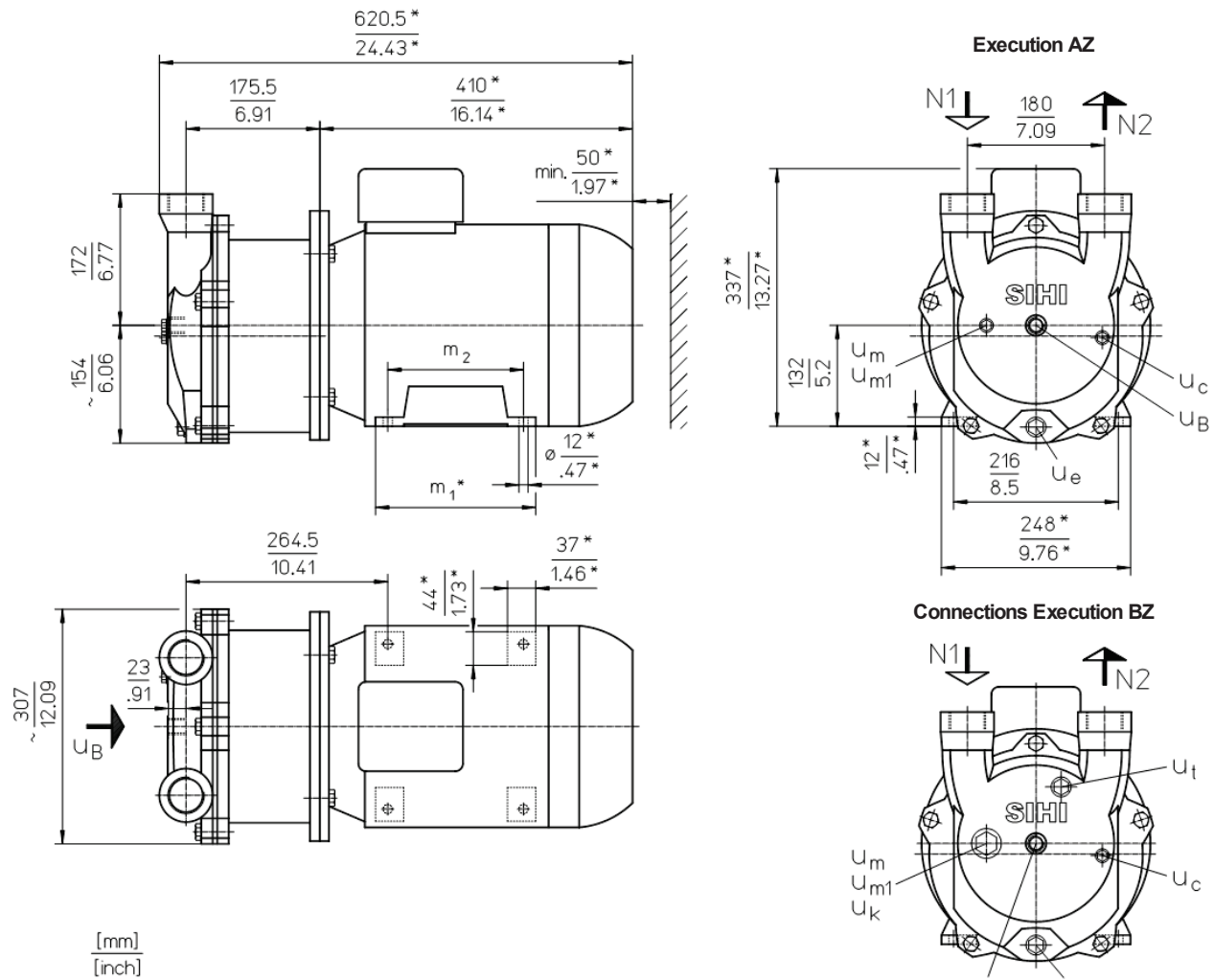

Dimensions in mm and inch

	Motor size	m ₁ [mm] / [in]	m ₂ [mm] / [in]	appr. weight [kg] / [lb]
LEM 162	132 S	170 / 6.69	140 / 5.51	112 / 247
	132 M	210 / 8.27	178 / 7.00	

Other motors on request

* Dimensions dependent upon motor supplier

Connections

LEM	Execution AZ		Execution BZ	
	162		162	
N 1 = Gas inlet	G 1 ½			
N 2 = Gas outlet				
u _B = Connection for service liquid control	G ½			
u _c = Connection for cavitation protection	G ¼			
u _e = Connection for drain	G ½			
u _m = Connection for manometer	G ¼		G 1	
u _{mt} = Connection for service liquid level				
u _k = Connection for condensation liquid	-		G ½	
u _t = Connection for thermometer	-			

Dimensions LEM 162, 252, 327, 427 with Flanged connections

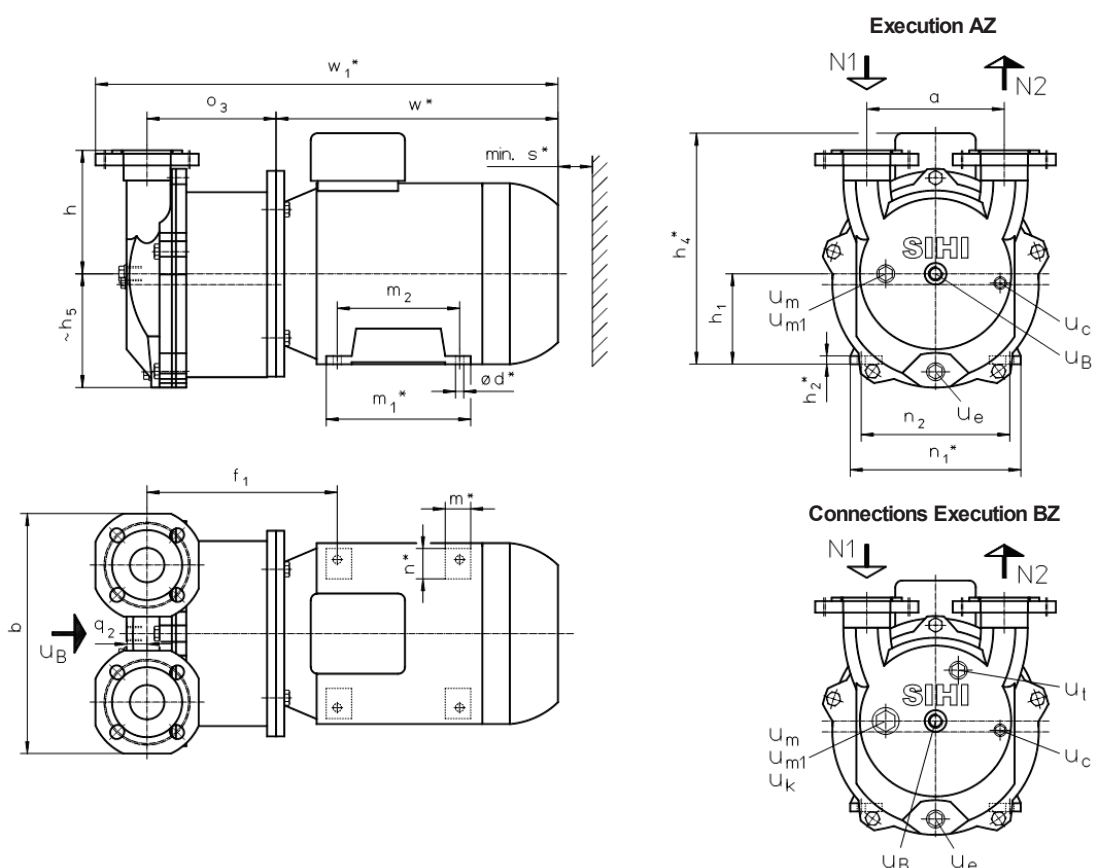

Dimensions in mm

	Motor size	a	b	d*	f ₁	h	h ₁	h ₂	h ₄	h ₅ *	m*	m ₁ *	m ₂ *	n*	n ₁ *	n ₂	o ₃	q ₂	s*	w*	w ₁ *	appr. weight [kg]
LEM 162	132 S	180	320	12	264.5	175	132	12	337	154	37	170	140	44	248	216	175.5	23	50	410	656	115
	132 M											210	178									
LEM 252	132 S	200	350	12	276.5	180	132	12	337	166	37	170	140	44	248	216	187.5	29	50	410	673	135
	132 M											210	178									
LEM 327	160 M	240	410	14,5	331	200	160	18	415	202	43	298	210	62	308	254	223	36	65	524	832	200
LEM 427	160 L												254									

Dimensions in inch

	Motor size	a	b	d*	f ₁	h	h ₁	h ₂	h ₄	h ₅ *	m*	m ₁ *	m ₂ *	n*	n ₁ *	n ₂	o ₃	q ₂	s*	w*	w ₁ *	appr. weight [lb]
LEM 162	132 S	7.09	12.60	0.47	10.41	6.89	5.2	0.47	13.27	6.06	1.46	6.69	5.51	1.73	9.76	8.5	6.91	0.91	1.97	16.14	25.81	254
	132 M											8.27	7.01									
LEM 252	132 S	7.87	13.78	0.47	10.89	7.09	5.2	0.47	13.27	6.54	1.46	6.69	5.51	1.73	9.76	8.5	7.38	1.14	1.97	16.14	26.48	298
	132 M											8.27	7.01									
LEM 327	160 M	9.45	16.14	0.57	13.03	7.87	6.3	0.71	16.34	7.95	1.69	11.73	8.27	2.44	12.13	10.0	8.78	1.42	2.56	20.63	32.76	441
LEM 427	160 L												10.0									

Other motors on request

* Dimensions dependent upon motor supplier

Dimensions LEM 162, 252, 327, 427 with Flanged connections

Flange dimensions according DIN EN 1092 PN 10 [mm]
Flanges drilled to ANSI 150 lbs [inch]

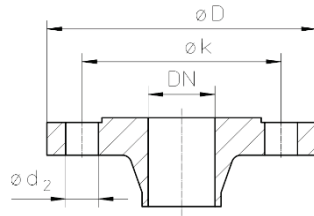

DN	40 mm 1 1/2"	50 mm 2"	65 mm 2 1/2"
k	110 mm 3.88 in	125 mm 4.75 in	145 mm 5.50 in
D	150 mm 5.91 in	165 mm 6.50 in	185 mm 7.28 in
Number x d_2	4 x 18 mm 4 x 0.63 in	4 x 18 mm 4 x 0.75 in	4 x 18 mm 4 x 0.75 in

Connections

LEM	Execution CZ			Execution DZ		
	162	252	327, 427	162	252	327, 427
N 1 = Gas inlet	DN 40 1 1/2"	DN 50 2"	DN 65 (4 holes) 2 1/2"	DN 40 1 1/2"	DN 50 2"	DN 65 (4 holes) 2 1/2"
N 2 = Gas outlet						
u _B = Connection for service liquid control	G 1/2		G 1	G 1/2		G 1
u _c = Connection for cavitation protection	G 1/4					
u _e = Connection for drain	G 1/2					
u _m = Connection for manometer	G 1/4	G 1/2	G 1/2	G 1		
u _{m1} = Connection for service liquid level						
u _k = Connection for condensation liquid	-					
u _t = Connection for thermometer	-					
				G 1/2		

Service liquid consumption in [m³/h] dependent on suction pressure, speed and temperature difference

Suction pressure [mbar]		33				120				200				400			
Pump type	Speed [rpm]	KB			FB	KB			FB	KB			FB	KB			FB
		Temperature difference [°C]				Temperature difference [°C]				Temperature difference [°C]				Temperature difference [°C]			
		10	5	2	10	5	2	10	5	2	10	5	2	10	5	2	
LEM 27	2900	0.05	0.08	0.16	0.45	0.06	0.10	0.18	0.41	0.06	0.10	0.18	0.38	0.06	0.10	0.17	0.30
	3500	0.07	0.12	0.21		0.08	0.13	0.22		0.08	0.14	0.22		0.08	0.13	0.20	
LEM 52	2900	0.07	0.12	0.22	0.45	0.10	0.15	0.25	0.41	0.10	0.16	0.24	0.38	0.10	0.15	0.22	0.32
	3500	0.10	0.17	0.27		0.12	0.19	0.28		0.13	0.19	0.27		0.12	0.18	0.24	
LEM 92	2900	0.12	0.20	0.33	0.60	0.13	0.21	0.33	0.53	0.14	0.21	0.32	0.48	0.13	0.20	0.29	0.41
	3500	0.17	0.26	0.40		0.18	0.27	0.38		0.18	0.26	0.36		0.17	0.24	0.32	
LEM 127	2900	0.14	0.23	0.37	0.60	0.17	0.25	0.37	0.53	0.17	0.25	0.35	0.48	0.16	0.23	0.31	0.41
	3500	0.20	0.30	0.43		0.21	0.31	0.41		0.21	0.29	0.38		0.20	0.27	0.34	
LEM 162	1450	0.24	0.40	0.66	1.20	0.23	0.39	0.67	1.10	0.27	0.42	0.65	1.00	0.27	0.41	0.61	0.90
	1750	0.28	0.45	0.72		0.31	0.49	0.73		0.32	0.49	0.70		0.32	0.47	0.66	
LEM 252	1450	0.28	0.46	0.76	1.30	0.31	0.48	0.73	1.10	0.32	0.48	0.70	1.00	0.31	0.47	0.65	0.90
	1750	0.36	0.56	0.85		0.38	0.57	0.80		0.39	0.56	0.76		0.38	0.54	0.71	
LEM 327	1450	0.35	0.58	0.98	1.80	0.40	0.63	0.94	1.40	0.42	0.63	0.92	1.30	0.40	0.58	0.81	1.10
	1750	0.49	0.77	1.17		0.52	0.75	1.04		0.52	0.75	1.00		0.50	0.68	0.88	
LEM 427	1450	0.46	0.73	1.13	1.80	0.51	0.74	1.03	1.40	0.52	0.74	1.00	1.30	0.49	0.68	0.88	1.10
	1750	0.61	0.91	1.30		0.63	0.87	1.13		0.64	0.85	1.08		0.60	0.78	0.94	

FB = Flow rate on once-through system

KB = Flow rate combined with partial recirculation at temperature differences of 10 °C, 5 °C, 2 °C warmer than make-up liquid.

Service liquid consumption in [US gpm] dependent on suction pressure, speed and temperature difference

Suction pressure [vac. in Hg]		28.9				26.0				24.0				18.0			
Pump type	Speed [rpm]	KB			FB	KB			FB	KB			FB	KB			FB
		Temperature difference [°F]				Temperature difference [°F]				Temperature difference [°F]				Temperature difference [°F]			
		18	9	4	18	9	4	18	9	4	18	9	4	18	9	4	
LEM 27	2900	0.22	0.35	0.70	1.98	0.26	0.44	0.79	1.81	0.26	0.44	0.79	1.67	0.26	0.44	0.75	1.32
	3500	0.31	0.53	0.92		0.35	0.57	0.97		0.35	0.62	0.97		0.35	0.57	0.88	
LEM 52	2900	0.31	0.53	0.97	1.98	0.44	0.66	1.10	1.81	0.44	0.70	1.06	1.67	0.44	0.66	0.97	1.41
	3500	0.44	0.75	1.19		0.53	0.84	1.23		0.57	0.84	1.19		0.53	0.79	1.06	
LEM 92	2900	0.53	0.88	1.45	2.64	0.57	0.92	1.45	2.33	0.62	0.92	1.41	2.11	0.57	0.88	1.28	1.81
	3500	0.75	1.14	1.76		0.79	1.19	1.67		0.79	1.14	1.59		0.75	1.06	1.41	
LEM 127	2900	0.62	1.01	1.63	2.64	0.75	1.10	1.63	2.33	0.75	1.10	1.54	2.11	0.70	1.01	1.37	1.81
	3500	0.88	1.32	1.89		0.92	1.37	1.81		0.92	1.28	1.67		0.88	1.19	1.50	
LEM 162	1450	1.06	1.76	2.91	5.28	1.01	1.72	2.95	4.84	1.19	1.85	2.86	4.40	1.19	1.81	2.69	3.96
	1750	1.23	1.98	3.17		1.37	2.16	3.21		1.41	2.16	3.08		1.41	2.07	2.91	
LEM 252	1450	1.23	2.03	3.35	5.72	1.37	2.11	3.21	4.84	1.41	2.11	3.08	4.40	1.37	2.07	2.86	3.96
	1750	1.59	2.47	3.74		1.67	2.51	3.52		1.72	2.47	3.35		1.67	2.38	3.13	
LEM 327	1450	1.54	2.55	4.32	7.93	1.76	2.77	4.14	6.16	1.85	2.77	4.05	5.72	1.76	2.55	3.57	4.84
	1750	2.16	3.39	5.15		2.29	3.30	4.58		2.29	3.30	4.40		2.20	2.99	3.87	
LEM 427	1450	2.03	3.21	4.98	7.93	2.25	3.26	4.54	6.16	2.29	3.26	4.40	5.72	2.16	2.99	3.87	4.84
	1750	2.69	4.01	5.72		2.77	3.83	4.98		2.82	3.74	4.76		2.64	3.43	4.14	

FB = Flow rate on once-through system

KB = Flow rate combined with partial recirculation at temperature differences of 18 °F, 9 °F, 4 °F warmer than make-up liquid.

Additional liquid carry-over

Pump type	max. liquid carry-over* (continuous operation)
LEM 27, 52, 92, 127	1.5 m³/h / 6.6 US gpm
LEM 162, 252, 327, 427	4.0 m³/h / 17.6 US gpm

* depending from suction pressure

Data regarding pump size – order hints

Range + size		Hydraulic + bearings	Shaft seal	Materials	Casing seal
		A• Threaded connections, standard B• as A•, but with additional connections* C• Flanged connections, standard D• as C•, but with additional connections* •Z two grease lubricated antifriction bearings arranged in the motor	D52, D4W Mechanical seal, elastomers Perbunan D5N, D4J, AFJ Mechanical seal, elastomers Viton	0F Main parts in cast iron, impeller in reinforced plastic - Engineered Polymer - POM 0E Main parts in cast iron, impeller in stainless steel VP Main parts in stainless steel, external screws in stainless steel, impeller in reinforced plastic - Engineered Polymer - POM VA Main parts in stainless steel, external screws in stainless steel, impeller in stainless steel	1 O-rings
LEMD	27	AZ, BZ	D52 D5N	0F, 0E, VP, VA	1
	52				
	92				
	127	D4W D4J	0F, 0E, VP, VA		
	162				
	162	CZ, DZ	D4W D4J AFJ	0F, 0E	
	252			VP, VA	
	327			0F, 0E, VP, VA	
	427				

* Recommended for the direct mounting of measurement devices for ATEX monitoring

Motor Selection

For our products we offer a lot of different motor types.
To identify the right motor please specify frequency, voltage and protection class.

Order example:

LEMD 52 AZ D52 0F 1 with 2.2 kW AC motor, 50 Hz, 230/400 Volt, IP 55

Any changes in the interest of the technical development are reserved.